

STRUGAL SOLAR

La protección solar más eficaz para las edificaciones contemporáneas.

A proteção solar mais eficaz para as edificações contemporâneas.

La protection solaire la plus efficace pour les bâtiments contemporains.

The most efficient solar protection for contemporary buildings.

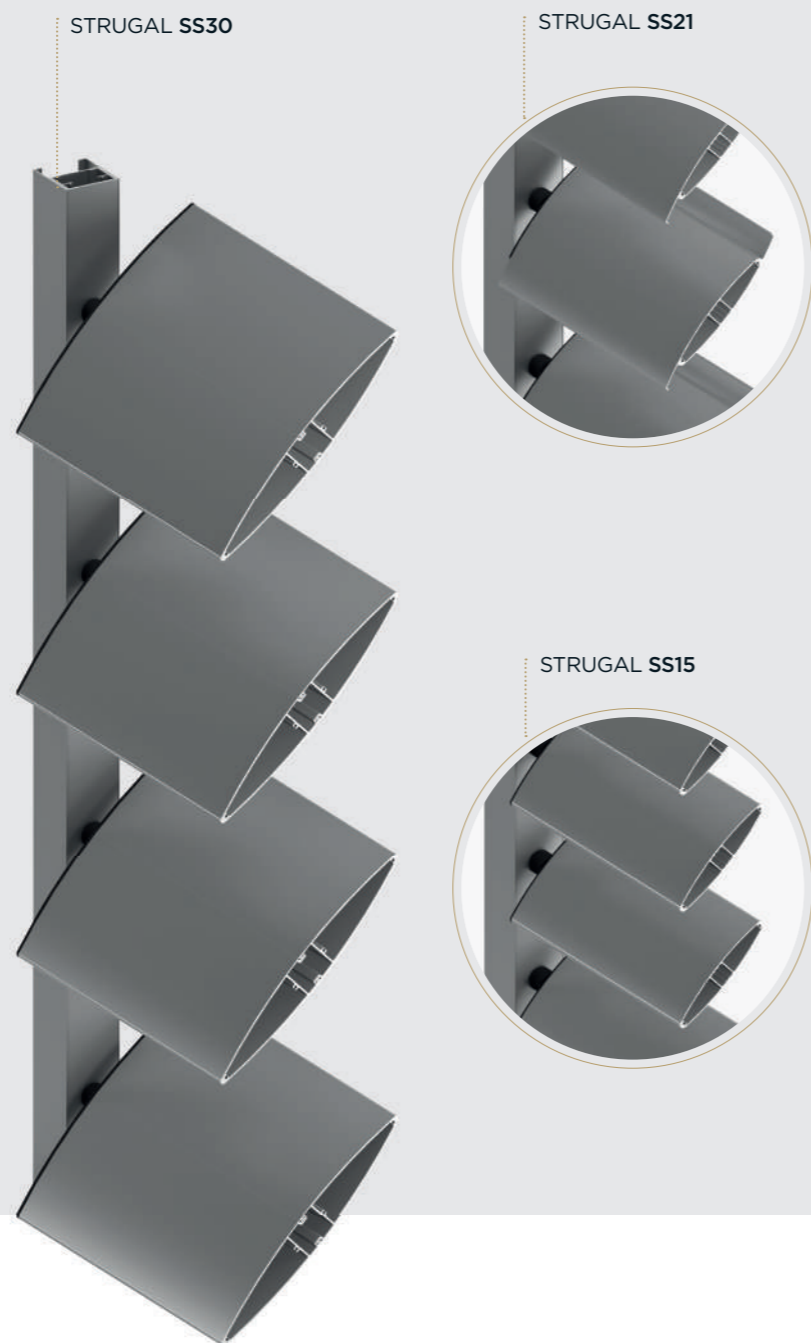

Lamas de protección solar con altas prestaciones y flexibilidad: diferentes diseños y tamaños de lamas, desde 150 mm hasta 300 mm. Con posibilidad de apertura manual o motorizada.

Lâminas de proteção solar com alto desempenho e flexibilidade: diferentes modelos e tamanhos de lâminas, de 150 mm a 300 mm. Com possibilidade de abertura manual ou motorizada.

Lames de protection solaire à hautes prestations et souplesse: différentes conceptions et dimensions de lames, de 150 mm à 300 mm. Avec possibilité d'ouverture manuelle ou motorisée.

Sun protection slats with high-performance features and flexibility: different slat designs and sizes, from 150mm to 300 mm. Manual or electrically-controlled.

CARACTERÍSTICAS TÉCNICAS

Características técnicas | Caractéristiques techniques | Technical characteristics

STRUGAL SOLAR

LAMAS MÓVILES

Lâminas móveis | Lames mobiles | Mobile slats

Posición horizontal

Posição horizontal | Position horizontale | Horizontal position

Posición vertical

Posição vertical | Position verticale | Vertical position

ANCHO DE PANEL

Largura do painel | Largeur de panneau | Panel width

Con pinzas

Com pinças | Avec pinces | With clamps

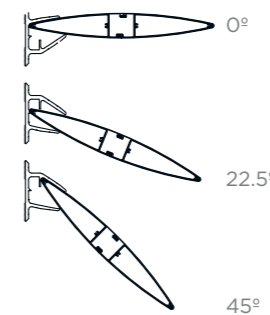
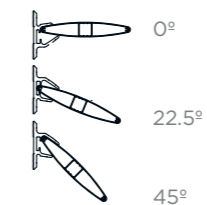

Con testeros

Com tampas laterais | Avec embouts | With head stocks

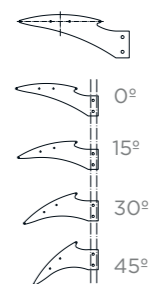
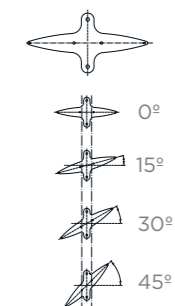

SECCIONES

Secções | Sections | Sections

